

# 600m/1000m Long-Distance Outdoor Laser Rangefinder Module

## Key Properties

- Max Range:  $\geq 600\text{m} / \geq 1000\text{m}$
- Min Range:  $\geq 3\text{m}$
- Measurement Frequency:  $\geq 3\text{ Hz}$
- Measurement Accuracy:  $< 100\text{m}: \pm 1\text{m}$   
 $\geq 100\text{m}: \pm(1+D \times 0.25\%)\text{m}$
- Wavelength: 905nm
- Divergence: 3mrad
- Laser Safety: Class 1
- Communication Interface: TTL (UART)



## Function

- Single Measurement
- Continuous Measurement
- Aiming Laser
- Angle Detection (Option)
- Baudrate Setting
- Address Setting

## Introduction

LRF00M3LSP is the advanced version of outdoor long-range laser rangefinder, featuring a reduced divergence angle to 3mrad and a wider operating temperature range. It offers a measurement range of up to 600/1000 meters and features a built-in red light for laser indication, making it convenient for users to aim at target objects. It also offers an angle sensing function option, which can be used to calculate the height or horizontal distance of the target object based on the ranging results.

The compact size and lightweight features make it convenient for OEM users to integrate into systems and equipment. Depending on the optical lens and circuit adjustments, we provide options for 600 and 1000 meters.

## 1. Specifications

Technical specifications	
Model Name	LRF600M3LSP / LRF1000M3LSP
Max Range	≥600m / ≥1000m
Min Range	≥3m
Measurement Frequency	≥3Hz
Measurement Accuracy	<100m: ±1m ≥100m: ±(1+Dx0.25%)m, D=distance
Detection Probability	≥98%
False Alarm Rate	≤1%
Optical Design	
Wavelength	905 nm
Aiming Laser Wavelength	650 nm
Beam Divergence	3 mrad
Laser Safety	905nm: Class 1 (IEC 60825-1:2014) 650nm: Class 3A (IEC 60825-1:2014)
Communication	
Communication Interface	3.3V TTL (UART)
Baud Rate	2400~115200 bps, default as 9600
Interface Connector	JST-SH 1.25mm 4P
Power Consumption	
Input Voltage	DC 3.3V±0.3V
Standby Power Consumption	≤150 mW
Operating Power Consumption	≤250 mW
Mechanical	
Dimensions	45 x 41 x 21 mm
Weight	38±3g
Environmental	
Operating Temperature	-40°C~60°C -10~50°C, Accuracy ±1m -20~-10°C, Accuracy ±2m -30~-20°C, Accuracy ±5m
Shock Resistance	800 g/1 ms (GJB150.16A-2009)
Electromagnetic Compatibility (EMC)	CE/FCC

### Note:

1. Measurement conditions: Target size ≥ 1.5m × 1.5m, reflectivity ≥ 85%, outdoor visibility greater than 5 km. (The effective range of the module is affected by target color, size, surface reflectivity and atmospheric visibility)
2. Product specifications support customization, if you require further assistance please contact us.

## 2. Pin Assignment

Red	V+	DC 3~3.3V
Green	RX	3.3V TTL (UART)
White	TX	3.3V TTL (UART)
Black	GND	Ground

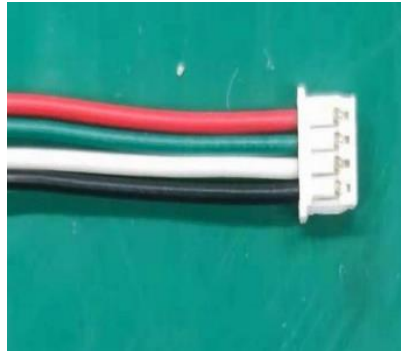

## 3. Dimensions

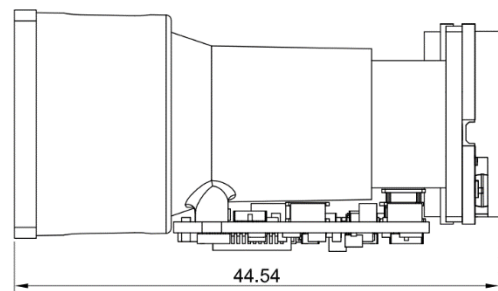
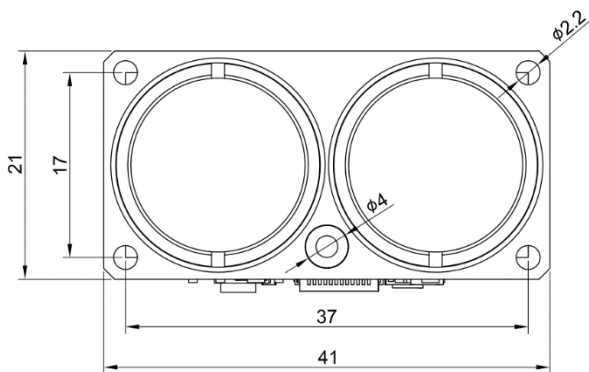
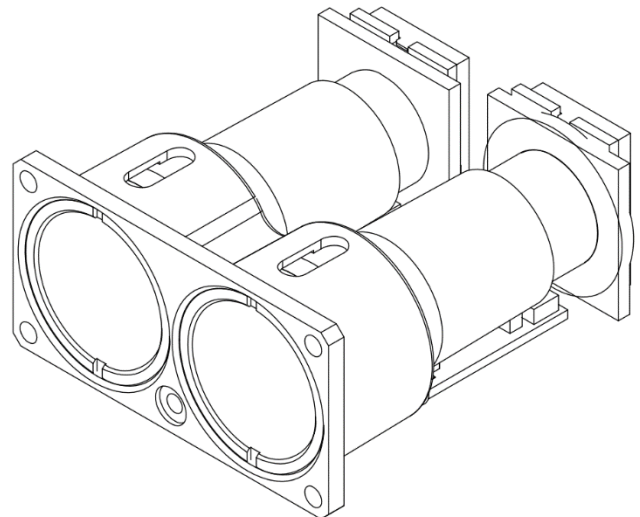
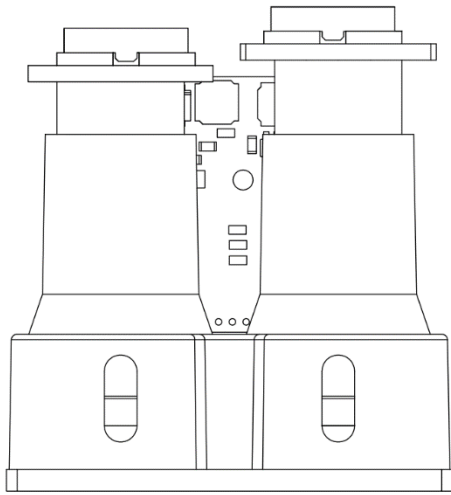

## 4. Communication

### 4.1 Communication frame format:

Head1 (1 byte)	Head2 (1 byte)	Data Length (1 byte)	Address (1 byte)	Command (1 byte)	Data (N byte)	Checksum (1 byte)	End1 (1 byte)	End2 (1 byte)
AE	A7						BC	BE

\*Head: Fixed as 0xAE 0xA7

\*Data Length: Length from Data Length to Checksum. (include checksum)

\*Address: Address of laser rangefinder module, default is 0x00.

\*Command: Command identification characters, please refer to Chapter 5.1 Command List.

\*Data: Data content, number of byte varies by command.

\*Checksum: Sum of Data Length, Address, Command and Data. (without carry).

\*End: Fixed as 0xBC 0xBE

### 4.2 UART configuration parameters:

8N1 with default 9600 baud rate, byte data are expressed in hexadecimal.

Data bits: 8

Parity bits: None

Stop bits: 1

## 5. Command

### 5.1 Command List

Master Command	
Command code	Description
0x01	Read Version
0x0A	Set BaudRate
0x0B	Set Address
0x05	Single Measurement
0x0E	Continuous Measurement
0x0F	Stop Measurement
0x40	Aiming Laser ON/OFF

Slave Response	
Recognition code	Description
0x81	Device Version
0x8A	BaudRate Setting Result
0x8B	Address Setting Result
0x85	Measurement Results
0xC0	Aiming Laser ON/OFF

## 5.2 Command Detail

### 5.2.1 Read Version

Master sends								
Head1 (1 byte)	Head2 (1 byte)	Data Length (1 byte)	Address (1 byte)	Command (1 byte)	Data (0 byte)	Checksum (1 byte)	End1 (1 byte)	End2 (1 byte)
0xAE	0xA7	0x04	0x00	0x01		0x05	0xBC	0xBE
Slave responses								
Head1 (1 byte)	Head2 (1 byte)	Data Length (1 byte)	Address (1 byte)	Command (1 byte)	Data (N byte)*	Checksum (1 byte)	End1 (1 byte)	End2 (1 byte)
0xAE	0xA7	*	0x00	0x81	VER*	*	0xBC	0xBE

\*N byte: The number of bytes is Data Length - 4.

\*VER: Version of module, format is ASCII and needs to be convert into string.

### 5.2.2 Set Baudrate

Master sends								
Head1 (1 byte)	Head2 (1 byte)	Data Length (1 byte)	Address (1 byte)	Command (1 byte)	Data (1 byte)	Checksum (1 byte)	End1 (1 byte)	End2 (1 byte)
0xAE	0xA7	0x05	0x00	0x0A	BAUD*	*	0xBC	0xBE

\*BAUD: 0x00 is 2400bps / 0x01 is 4800bps / 0x02 is 9600bps / 0x03 is 19200bps  
 0x04 is 38400bps / 0x05 is 57600bps / 0x06 is 115200bps

\*Default baudrate is 9600bps.

\*After changing the baudrate, the module needs to be re-powered to take effect.

Slave responses								
Head1 (1 byte)	Head2 (1 byte)	Data Length (1 byte)	Address (1 byte)	Command (1 byte)	Data (0 byte)	Checksum (1 byte)	End1 (1 byte)	End2 (1 byte)
0xAE	0xA7	0x04	0x00	0x8A		08E	0xBC	0xBE

### 5.2.3 Set Address

Master sends								
Head1 (1 byte)	Head2 (1 byte)	Data Length (1 byte)	Address (1 byte)	Command (1 byte)	Data (1 byte)	Checksum (1 byte)	End1 (1 byte)	End2 (1 byte)
0xAE	0xA7	0x05	0x00	0x0B	ADDR*	*	0xBC	0xBE
Slave responses								
Head1 (1 byte)	Head2 (1 byte)	Data Length (1 byte)	Address (1 byte)	Command (1 byte)	Data (0 byte)	Checksum (1 byte)	End1 (1 byte)	End2 (1 byte)
0xAE	0xA7	0x04	ADDR*	0x8B			0xBC	0xBE

\*ADDR: Address of module, setting range is 0x01~0xEF.

\*0x00 is a general broadcast address, if you forget the module address, you can still use 0x00 to control the module.

### 5.2.4 Single Measurement

Master sends								
Head1 (1 byte)	Head2 (1 byte)	Data Length (1 byte)	Address (1 byte)	Command (1 byte)	Data (0 byte)	Checksum (1 byte)	End1 (1 byte)	End2 (1 byte)
0xAE	0xA7	0x04	0x00	0x05		0x09	0xBC	0xBE
Slave responses								
*Please refer to <b>Chapter 5.2.6</b> Measurement Result								

### 5.2.5 Continuous Measurement

Master sends								
Head1 (1 byte)	Head2 (1 byte)	Data Length (1 byte)	Address (1 byte)	Command (1 byte)	Data (0 byte)	Checksum (1 byte)	End1 (1 byte)	End2 (1 byte)
0xAE	0xA7	0x04	0x00	0x05		0x09	0xBC	0xBE
*Once module received command it will responds AE A7 04 00 8E 92 BC BE and then starts continuous measurement.								
Slave responses								
*Please refer to <b>Chapter 5.2.6</b> Measurement Result								

### 5.2.6 Measurement Result

Slave responses								
Head1 (1 byte)	Head2 (1 byte)	Data Length (1 byte)	Address (1 byte)	Command (1 byte)	Data (19 byte)	Checksum (1 byte)	End1 (1 byte)	End2 (1 byte)
0xAE	0xA7	0x17	0x00	0x85	MMSG*	*	0xBC	0xBE
*MMSG: Measurement results, definitions are as follows table.								
byte1~2	Elevation Angle	(byte1x256 + byte2)/10, example: 0x00 0xAE means Elevation Angle is 17.4 degrees						
byte3~4	Straight Distance	(byte3x256 + byte4)/10, example: 0x02 0x68 means Straight Distance is 61.6 meter						
byte5~6	Height	(byte5x256 + byte6)/10, example: 0x00 0xB8 means Height is 18.4 meter						
byte7~8	Horizontal Distance	(byte7x256 + byte8)/10, example: 0x02 0x4C means Horizontal Distance is 58.8 meter						
byte9~18	Reserved	Fixed as 0x00 (reserved for customization)						
byte 19	Distance Unit	Fixed as 0x01, means meter.						

\*Slave Response on failure in Single Measurement : AE A7 04 00 05 09 BC BE.

\*Slave Response on failure in Continues Measurement : AE A7 04 00 05 09 BC BE.

\*The red row is available only in tilt sensor integrated version, the version without tilt sensor is fixed as 0x00.

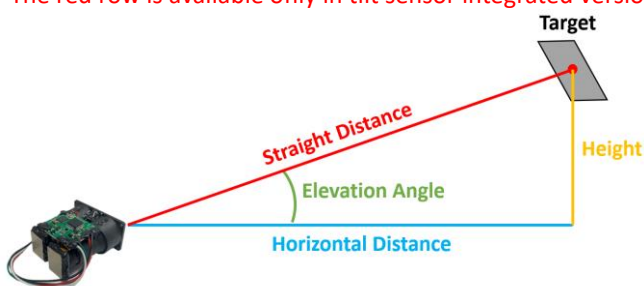

### 5.2.7 Stop Measurement

Master sends								
Head1 (1 byte)	Head2 (1 byte)	Data Length (1 byte)	Address (1 byte)	Command (1 byte)	Data (0 byte)	Checksum (1 byte)	End1 (1 byte)	End2 (1 byte)
0xAE	0xA7	0x04	0x00	0x0F		0x13	0xBC	0xBE
Slave responses								
Head1 (1 byte)	Head2 (1 byte)	Data Length (1 byte)	Address (1 byte)	Command (1 byte)	Data (0 byte)	Checksum (1 byte)	End1 (1 byte)	End2 (1 byte)
0xAE	0xA7	0x04	0x00	0x8F		0x93	0xBC	0xBE

### 5.2.8 Aiming Laser ON/OFF

Master sends								
Head1 (1 byte)	Head2 (1 byte)	Data Length (1 byte)	Address (1 byte)	Command (1 byte)	Data (1 byte)	Checksum (1 byte)	End1 (1 byte)	End2 (1 byte)
0xAE	0xA7	0x05	0x00	0x40	DATA*	*	0xBC	0xBE
*DATA: 0x01 for Aiming Laser <b>ON</b> , 0x00 for Aiming Laser <b>OFF</b>								
Slave responses								
Head1 (1 byte)	Head2 (1 byte)	Data Length (1 byte)	Address (1 byte)	Command (1 byte)	Data (0 byte)	Checksum (1 byte)	End1 (1 byte)	End2 (1 byte)
0xAE	0xA7	0x04	0x00	0xC0		0xC4	0xBC	0xBE